

ARROW (IN-SWING ONLY) TYPE

FABRICATED ACCESS DOOR

AHH -10
-15
-20

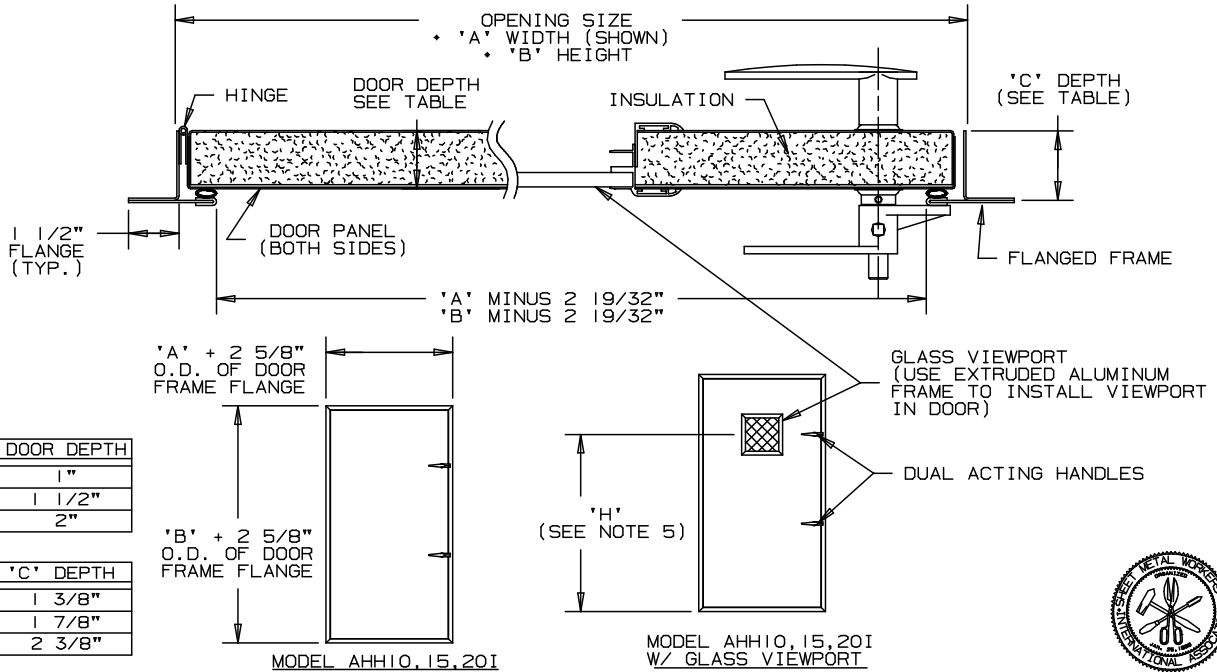

SCHEDULE

ITEM	QTY	MODEL				OPENING SIZE		NON-STANDARD VIEWPORT LOCATION ** (SEE NOTE 5) 'H' (WHEN REQ'D)	IDENTIFICATION
		AHH	L/H	R/H	10	15	20		
		AHH					I		
		AHH					I		

NOTES

- HINGE ALWAYS FURNISHED ON 'B' HEIGHT DIMENSION.
- (G) DESIGNATES DOORS WITH GLASS VIEWPORTS, SPECIFY (L/H) LEFT HAND OR (R/H) RIGHT HAND HINGE WHEN VIEWING FROM THE OUTSIDE.
- 9" x 9" GLASS VIEWPORT NOT AVAILABLE ON UNITS UNDER 18" IN WIDTH AND 12" x 12" VIEWPORTS NOT AVAILABLE ON UNITS UNDER 21" IN WIDTH.
- UNLESS OTHERWISE SPECIFIED, DOOR WILL BE FABRICATED 1/4" UNDER LISTED SIZE. DIMENSIONAL TOLERANCE IS ±.075.
- UNLESS OTHERWISE SPECIFIED, STANDARD VIEWPORT LOCATIONS ARE AS FOLLOWS:
'H'='B'-11" (±1") WHEN 'B' IS 20" TO 60"
'H'='B'-48" (±1") WHEN 'B' IS GREATER THAN 60"
WHEN SPECIFYING NON-STANDARD VIEWPORT LOCATIONS, 'H' CANNOT BE GREATER THAN 'B'-11"
- MINIMUM SIZE 12" WIDE x 12" HIGH
MAXIMUM SIZE 48" WIDE x 96" HIGH
(WIDTH CANNOT EXCEED 2x HEIGHT)
- OPTIONAL MATERIALS AVAILABLE FOR THE FOLLOWING COMPONENTS:
DOOR PANELS-BONDERIZED STEEL,
OR STAINLESS STEEL
VIEWPORT GLASS-SINGLE PANE: 1/4" PLEXIGLASS
DOUBLE PANE: 1/4" WIRE
1/4" WIRE THERMAL PANE
HANDLES-CHROME PLATED
- PLEASE REFER TO INSTALLATION INSTRUCTIONS FOR MOUNTING OF HANDLES, AND DOOR ASSEMBLY MOUNTING.
- IN-SWING DOORS ARE RECOMMENDED FOR POSITIVE PRESSURES, OUT-SWING DOORS ARE RECOMMENDED FOR NEGATIVE PRESSURES

SPECIFICATIONS

SPECIFICATIONS			PROJECT/LOCATION
FLANGED FRAME 16 GA GALV. STEEL	INSULATION 2.25 LB. DENSITY POLYURETHANE FOAM	HINGE STAINLESS STEEL CONTINUOUS TYPE - IN SWING	ARCHITECT/ENGINEER
DOOR PANELS 20 GA GALV. STEEL	HANDLES DUAL ACTING DIE CAST ZINC	VIEWPORT GLASS (SINGLE PANE) 1/4" WIRE (9"x9" STANDARD) (12"x12" OPTIONAL)	CONTRACTOR
CHANNEL SUPPORT 16 GA GALV. STEEL	GASKET CONTINUOUS LENGTH REPLACEABLE NEOPRENE BULB	FINISH MILL	SALES ENGINEER
FABRICATED ACCESS DOOR-MODELS AHH10,15,20I			 ARROW UNITED INDUSTRIES A DIVISION OF MESTEK, INC. 314 RIVERSIDE DRIVE WYALUSING, PA 18853 TEL: (570) 746-1888 FAX: (570) 746-9286
DRAWN BY LCC			DRAWING NO.
DATE 3/18/02			9-401

ARROW (OUT-SWING ONLY)

TYPE

FABRICATED ACCESS DOOR

AHH -10
-15
-20

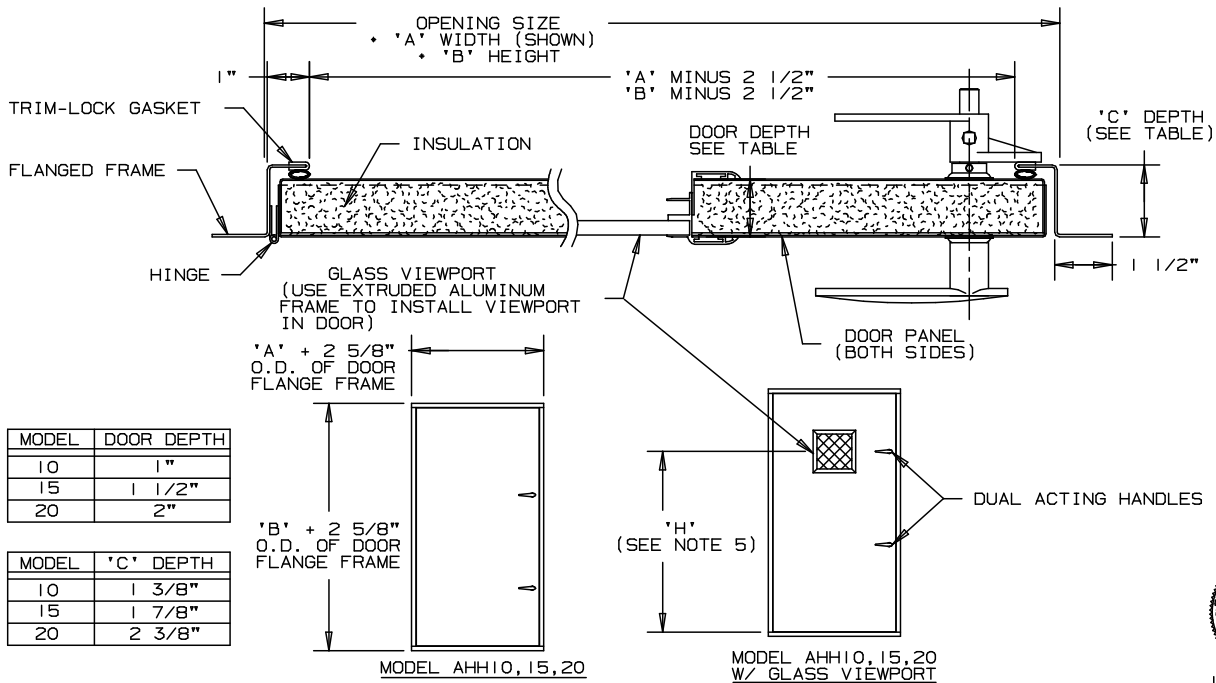

SCHEDULE

ITEM	QTY	MODEL			OPENING SIZE		NON-STANDARD VIEWPORT LOCATION ** (SEE NOTE 5) 'H' (WHEN REQ'D)	IDENTIFICATION
		AHH	10	15	20	**VIEWPORT L/H R/H		
		AHH						
		AHH						

NOTES

- HINGE ALWAYS FURNISHED ON 'B' HEIGHT DIMENSION.
- (G) DESIGNATES DOORS WITH GLASS VIEWPORTS, SPECIFY (L/H) LEFT HAND OR (R/H) RIGHT HAND HINGE WHEN VIEWING FROM THE OUTSIDE.
- 9" x 9" GLASS VIEWPORT NOT AVAILABLE ON UNITS UNDER 18" IN WIDTH AND 12" x 12" VIEWPORTS NOT AVAILABLE ON UNITS UNDER 21" IN WIDTH.
- UNLESS OTHERWISE SPECIFIED, DOOR WILL BE FABRICATED 1/4" UNDER LISTED SIZE. DIMENSIONAL TOLERANCE IS ±.075.
- UNLESS OTHERWISE SPECIFIED, STANDARD VIEWPORT LOCATIONS ARE AS FOLLOWS:
'H' = 'B' - 11" (±1") WHEN 'B' IS 20" TO 60"
'H' = 48" (±1") WHEN 'B' IS GREATER THAN 60"
WHEN SPECIFYING NON-STANDARD VIEWPORT LOCATIONS, 'H' CANNOT BE GREATER THAN 'B' - 11"
- MINIMUM SIZE 12" WIDE x 12" HIGH
MAXIMUM SIZE 48" WIDE x 96" HIGH
(WIDTH CANNOT EXCEED 2x HEIGHT)
- OPTIONAL MATERIALS AVAILABLE FOR THE FOLLOWING COMPONENTS:
DOOR PANELS - BONDERIZED STEEL, OR STAINLESS STEEL
VIEWPORT GLASS - SINGLE PANE: 1/4" PLEXIGLASS
DOUBLE PANE: 1/4" WIRE
1/4" WIRE THERMAL PANE
HANDLES - CHROME PLATED
- PLEASE REFER TO INSTALLATION INSTRUCTIONS FOR MOUNTING OF HANDLES, AND DOOR ASSEMBLY MOUNTING.
- IN-SWING DOORS ARE RECOMMENDED FOR POSITIVE PRESSURES, OUT-SWING DOORS ARE RECOMMENDED FOR NEGATIVE PRESSURES

SPECIFICATIONS

FLANGED FRAME 16 GA GALV. STEEL			INSULATION 2.25 LB. DENSITY POLYURETHANE FOAM			HINGE STAINLESS STEEL CONTINUOUS TYPE - OUT SWING			PROJECT/LOCATION		
DOOR PANELS 20 GA GALV. STEEL			HANDLES DUAL ACTING DIE CAST ZINC			VIEWPORT GLASS (SINGLE PANE) 1/4" WIRE (9"x9" STANDARD) (12"x12" OPTIONAL)			ARCHITECT/ENGINEER		
CHANNEL SUPPORT 16 GA GALV. STEEL			GASKET CONTINUOUS LENGTH REPLACEABLE NEOPRENE BULB			FINISH MILL			CONTRACTOR		
									SALES ENGINEER		
									ARROW UNITED INDUSTRIES A DIVISION OF MESTEK, INC. 314 RIVERSIDE DRIVE WYALUSING, PA 18853 TEL: (570) 746-1888 FAX: (570) 746-9286		

FABRICATED ACCESS DOOR-MODELS AHH10, 15, 20

DRAWN BY LCC
DATE 3/15/02

DRAWING NO. 9-400