

ARROW EXTRUDED ALUMINUM ARROW-FOIL DAMPERS CLASS "IA" AIR LEAKAGE RATED

TYPE AFD-20

SPECIFICATIONS

DAMPERS SHALL BE ARROW-FOIL DAMPER MODEL AFD-20 AS MANUFACTURED BY ARROW UNITED INDUSTRIES, WYALUSING, PA 18853. LOW LEAKAGE DAMPER SHALL BEAR THE AMCA CERTIFIED RATINGS SEAL FOR AIR LEAKAGE AND AIR PERFORMANCE. HAVING LEAKAGE THROUGH A 60"x36" DAMPER AT 4" WATER GAUGE PRESSURE DIFFERENTIAL EQUAL TO CLASS I LEAKAGE.

FRAMES AND BLADES TO BE A MINIMUM 12 GA (.081") EXTRUDED ALUMINUM. BLADES TO BE A SINGLE UNIT ARROW-FOIL DESIGN, 6" WIDE WITH THE PIN-LOCK AN INTEGRAL SECTION WITHIN THE BLADE CORE.

OVERLAP BLADES AND SEALS (NOT JUST OVERLAP SEALS) ASSURE MINIMUM AIR LEAKAGE. SILICONE SEALS FIT INTO RIBBED GROOVE INSERT IN BLADES WITH A FORMED STAINLESS STEEL, SPRING STEEL SEAL AT THE JAMB.

FRAMES TO BE EXTRUDED ALUMINUM "HAT-SHAPED" CHANNEL WITH REINFORCING BOSSES AND GROOVE INSERTS FOR SILICONE SEALS. STANDARD FRAMES ARE 5" WIDE "HAT-SHAPED" FRAMES TYPICAL (4) SIDES.

AXLE SHAFTS TO BE 1/2" DIA. EXTRUDED ALUMINUM, PIN-LOCK DESIGN INTERLOCKING INTO BLADE SECTION. BEARINGS TO BE "DOUBLE-SEALED" TYPE WITH CELCON INNER BEARING ON AXLE RIDING IN POLYCARBONATE OUTER BEARING INSERTED IN FRAME SO THAT OUTER BEARING CANNOT ROTATE.

AXLE BEARINGS TO BE DESIGNED SO THAT THERE SHALL BE NO METAL-TO-METAL OR METAL-TO-BEARING RIDING SURFACES. INTERCONNECTING LINKAGE TO HAVE CELCON BEARINGS TO ELIMINATE FRICTION IN LINKAGE.

LINKAGE CONTAINED WITHIN THE JAMB CONSISTS OF A HEAVY, ALUMINUM CRANK-ARM PERMANENTLY LOCKED TO THE BLADE SHAFT BY TWO STAINLESS STEEL FASTENERS. THE CRANK-ARM CONTAINS A 1/2" DIA. CADMIUM PLATED & CHROMATE TREATED MACHINED STEEL TRUNNION RIDING IN A CELCON BEARING. A PLATED STEEL 1/4-20 SET SCREW WITH LOCKING PATCH, TIES THE PIVOT TO THE 5/16" DIA. ALUMINUM LINKAGE ROD. THE LINKAGE OF EACH DAMPER IS INDIVIDUALLY ADJUSTED.

MIN. SIZE: 12"W X 12"H - SINGLE BLADED
MIN. SIZE: 12"W X 14 5/8"H - 2 BLADE OPP.
MAX. SIZE: 60"W X 72"H - MULTIPANEL SECTIONS FOR LARGER THAN MAX. SINGLE PANEL SECTION IS RECOMMENDED.

PLEASE SPECIFY WHETHER PARALLEL OR OPPOSED OPERATION IS REQUIRED. NOT RECOMMENDED FOR BLADES INSTALLED VERTICALLY.

NOMINAL DEDUCTIONS WILL BE MADE TO THE OPENING SIZE GIVEN.

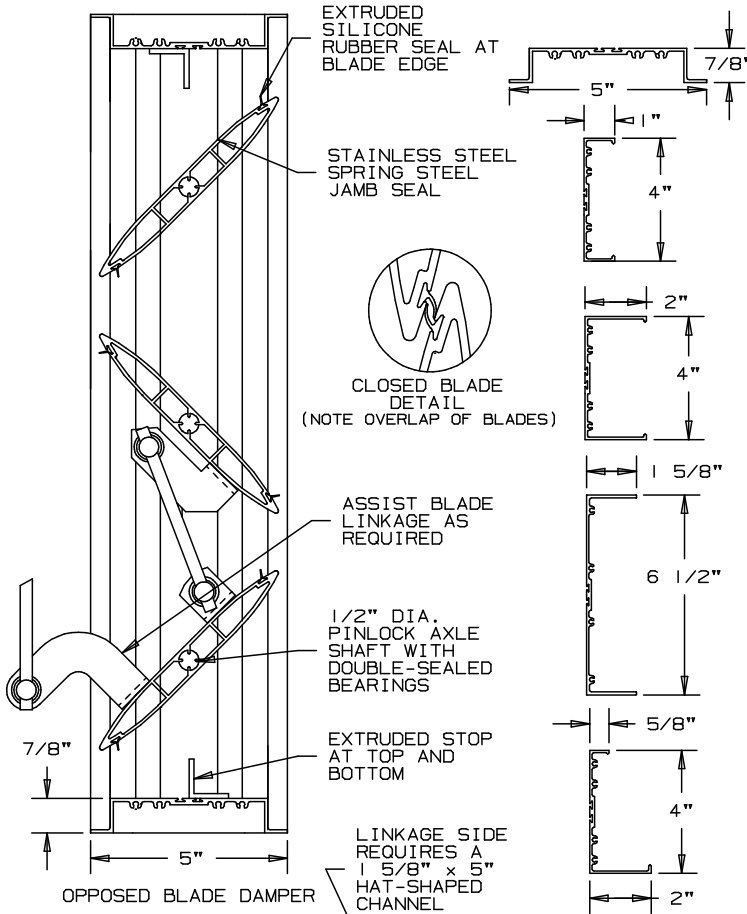

OPTIONAL FRAMES
.125" NOMINAL THICKNESS

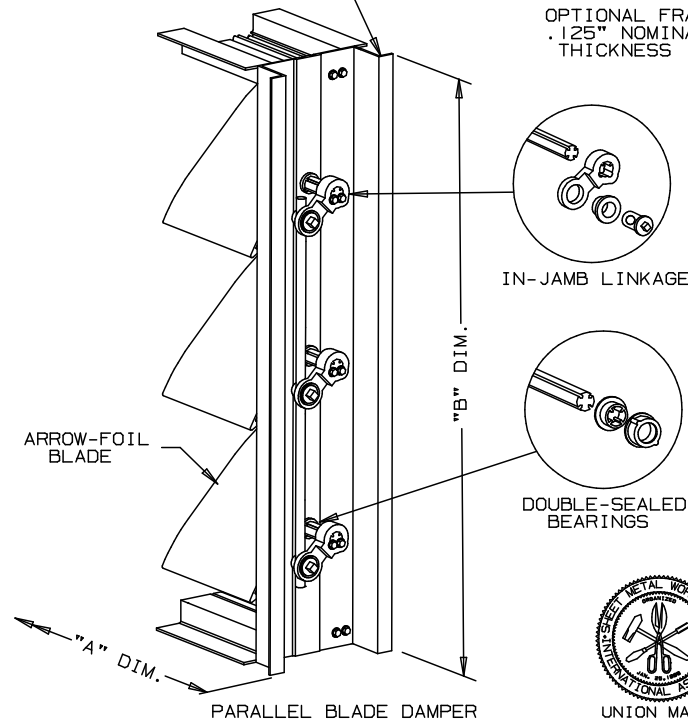

SCHEDULE

ITEM	QTY.	"A" DIM.	"B" DIM.



ARROW UNITED INDUSTRIES
A DIVISION OF MESTEK, INC.

314 RIVERSIDE DRIVE
WYALUSING, PA 18853

TEL: (570) 746-1888 FAX: (570) 746-9286

AGENT: _____

ARCH./ENG.:

CONTR.:

PROJECT:

EDR: ECN: JOB:

DATE: DWN.: DWG.:



UNION MADE

DAMPER MODEL AFD-20

EXTRUDED ALUMINUM - PARALLEL - OPPOSED

PERFORMANCE DATA

PRESSURE DROP

PRESSURE DROP RATINGS ARE BASED ON AMCA STANDARD 500 USING TEST SET-UP FIG. 5.3 FOR DAMPER INSTALLED WITH DUCT UPSTREAM AND DOWNSTREAM. STATIC PRESSURES ARE CORRECTED TO .075 LB./CU. FT. AIR DENSITY.

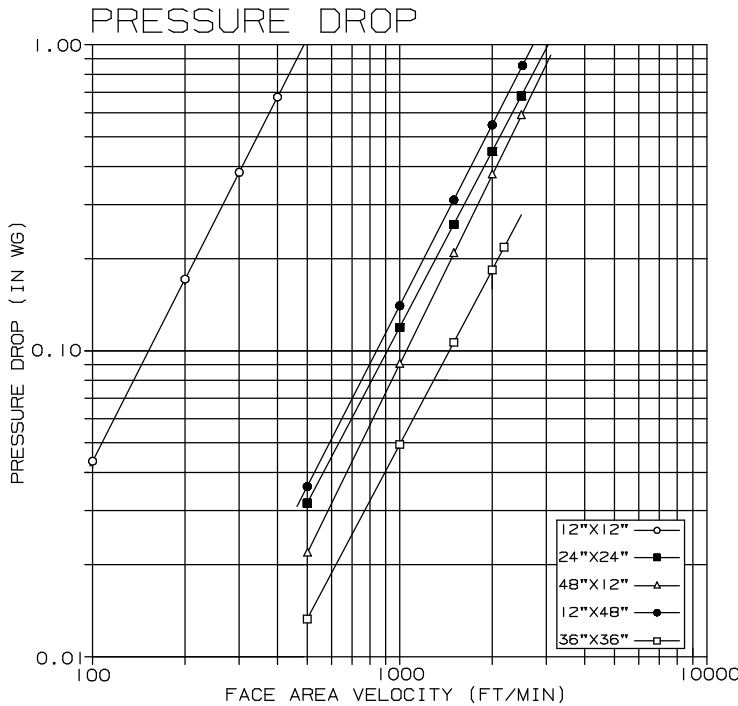

12" x 12"	
FACE AREA VELOCITY (ft/min)	PRESSURE DROP (in wg)
100	0.04
200	0.16
300	0.38
400	0.69
500	1.00

24" x 24"	
FACE AREA VELOCITY (ft/min)	PRESSURE DROP (in wg)
500	0.03
1000	0.12
1500	0.25
2000	0.45
2500	0.68

12" x 48"	
FACE AREA VELOCITY (ft/min)	PRESSURE DROP (in wg)
500	0.04
1000	0.14
1500	0.31
2000	0.56
2500	0.85

48" x 12"	
FACE AREA VELOCITY (ft/min)	PRESSURE DROP (in wg)
500	.02
1000	.09
1500	.20
2000	.38
2500	.58

36" x 36"	
FACE AREA VELOCITY (ft/min)	PRESSURE DROP (in wg)
500	0.01
1000	0.05
1500	0.10
2000	0.18
2200	0.21

LEAKAGE

AIR LEAKAGE REQUIREMENTS MEET INTERNATIONAL ENERGY CONSERVATION CODE (IECC) BY LEAKING LESS THAN 3 CFM/SQ.FT. AT 1" OF STATIC PRESSURE AND IS AMCA LICENSED AS A CLASS "IA" DAMPER.

DAMPER SIZE WIDTH x HEIGHT	1 IN W.G. CLASS	4 IN W.G. CLASS
12" x 12"	IA	I
24" x 24"	IA	I
36" x 36"	IA	I
12" x 48"	IA	I
48" x 12"	IA	I
60" x 36"	IA	I

LEAKAGE RATINGS ARE BASED ON AMCA STANDARD 500 USING TEST SET-UP FIG. 5.5 AT AN OPERATION TEMPERATURE RANGE BETWEEN 50°F & 104°F. DATA ARE BASED ON A SEATING TORQUE OF 40 LB/IN. FOR DAMPERS LESS THAN 4 SQ. FT. IN SIZE. DAMPERS ABOVE 4 SQ. FT., 5 LB/IN/SQ.FT. IS APPLIED TO HOLD THE DAMPER IN THE CLOSED POSITION.

DAMPER AIR LEAKAGE CLASSIFICATION

CLASS	PRESSURE	LEAKAGE, CFM/FT ²	
		REQUIRED RATING	
		1 IN. W.G.	4 IN. W.G.
IA		3	NA
I		4	8
2		10	20
3		40	80



ARROW UNITED INDUSTRIES CERTIFIES THAT THE MODEL AFD-20 DAMPER SHOWN HEREIN IS LICENSED TO BEAR THE AMCA SEAL. THE RATINGS SHOWN ARE BASED ON TESTS AND PROCEDURES PERFORMED IN ACCORDANCE WITH AMCA PUBLICATION 511 AND COMPLY WITH THE REQUIREMENTS OF THE AMCA CERTIFIED RATINGS PROGRAM. THE AMCA CERTIFIED RATING SEAL APPLIES TO AIR PERFORMANCE/AIR LEAKAGE ONLY.

DAMPER MODEL AFD-20

EXTRUDED ALUMINUM - PARALLEL - OPPOSED

PERFORMANCE DATA

LINEAR AIR FLOW CHARACTERISTICS

ARROW UNITED INDUSTRIES HAS TESTED A VARIETY OF ARROWFOIL BLADE WIDTHS 4", 5", & 6" IN VARIOUS ARRANGEMENTS FROM ALL PARALLEL, ALL OPPOSED, AND COMBINATIONS OF PARALLEL AND OPPOSED BLADES IN A COMMON FRAME FOR A SINGLE DAMPER INSTALLED IN A DUCT.

TEST UNITS WERE INSTALLED IN DUCTWORK WITH DUCT UPSTREAM AND DOWNSTREAM PER AMCA TEST SET-UP FIG. 5.3. USING MOST COMMON APPROACH VELOCITIES AND FAN STATIC PRESSURES TO CONDUCT LINEAR AIR FLOW TEST.

THE RESULTS OF THE TESTS SHOW THAT FAN STATIC PRESSURE DOES HAVE AN EFFECT ON THE LINEAR AIR FLOW CHARACTERISTICS OF A DAMPER. GRAPHS BELOW WILL IDENTIFY THE SIMULATED SYSTEM CONDITIONS USED FOR THE SINGLE DAMPER IN DUCT SYSTEM APPLICATION.

CURVES SHOWN IN THE GRAPHS BELOW SHOW THAT MODEL AFD-20 ALL OPPOSED, "AS STANDARDLY BUILT", IS A VERY EFFECTIVE CONTROL DAMPER FOR USE IN A VARIETY OF VELOCITIES AND PRESSURES.

