

ARROW EXTRUDED ALUMINUM LOUVERS 4" DEEP

TYPE C-33

CHEVRON-SIGHTPROOF-STANDARD CHANNEL TYPE

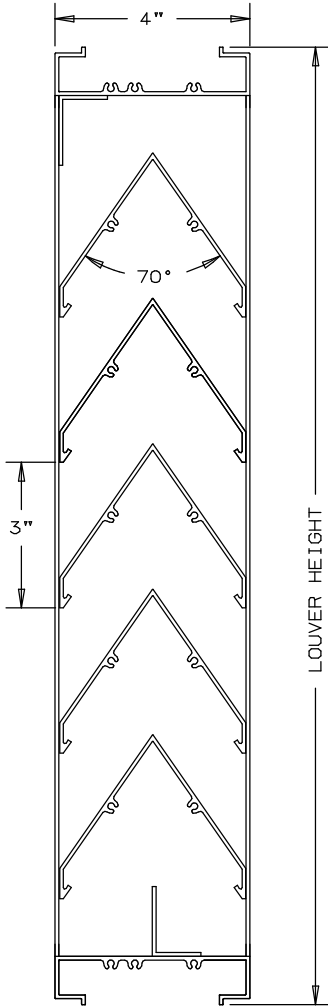

NOT TO SCALE

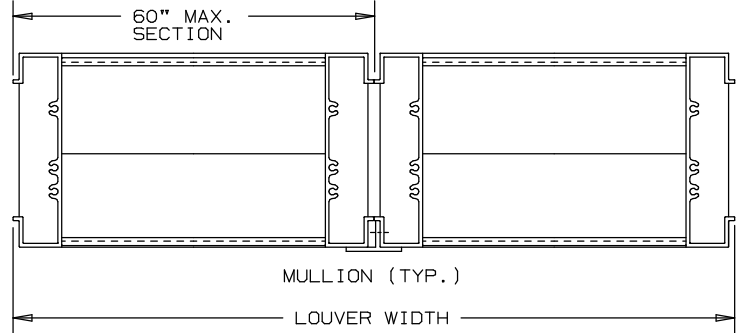

SPECIFICATIONS

MATERIAL: EXTRUDED ALUMINUM 6063-T6/T52 ALLOY
.081" THK.

FACE OF LOUVER: ALL SURFACES ARE FLUSH. WITH JAMBS
CONTAINED WITHIN THE HEAD AND SILL.

SCREEN: (WHEN INDICATED)
BIRD SCREEN - 1/2" FLATTENED ALUMINUM, .051" THK.
OR - 1/2" SQ. MESH INTERMEDIATE DOUBLE-
CRIMPED ALUMINUM WIRE, .063" DIA.
OR - 18/16 MESH, .011" DIA. ALUMINUM
WIRE INSECT SCREEN.

FINISH: _____

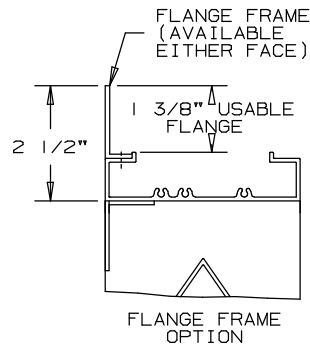

NOMINAL DEDUCTIONS WILL BE MADE TO OPENING SIZES GIVEN.

ITEM	QTY.	WIDTH	HEIGHT	WIDTH	HEIGHT	MULL	TYPE	LOC	SCREENS	 UNION MADE
		OPENING SIZE		LOUVER SIZE						

ARROW UNITED INDUSTRIES
A DIVISION OF MESTEK, INC.
314 RIVERSIDE DRIVE
WYALUSING, PA 18853
TEL: (570) 746-1888 FAX: (570) 746-9286

AGENT: _____

ARCH./ENG. : _____
CONTR. : _____
PROJECT : _____
EDR: _____ ECN: _____ JOB: _____
DATE: _____ DWN. : _____ DWG. : _____

LOUVER MODEL C-33 CHEVRON BLADE EXTRUDED ALUMINUM - STATIONARY

PERFORMANCE DATA

RATINGS DO NOT INCLUDE THE EFFECT OF BIRDSCREEN.

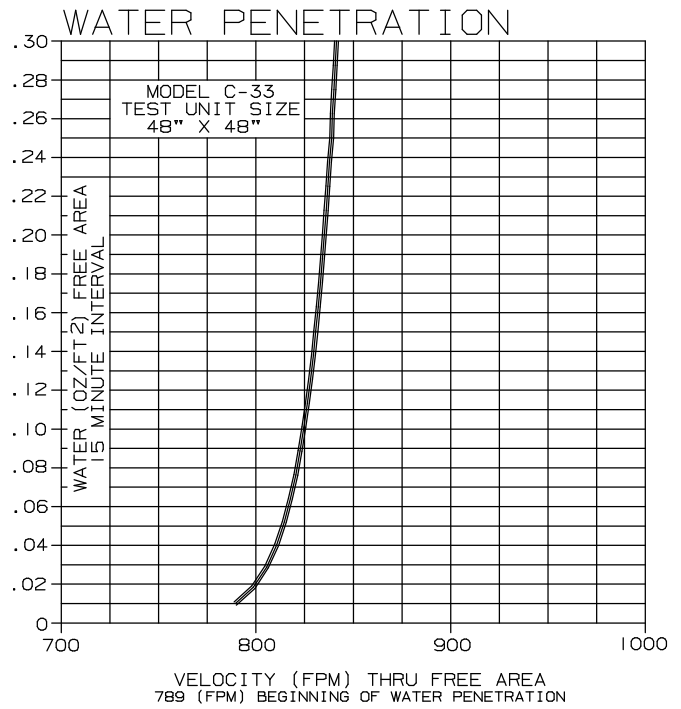
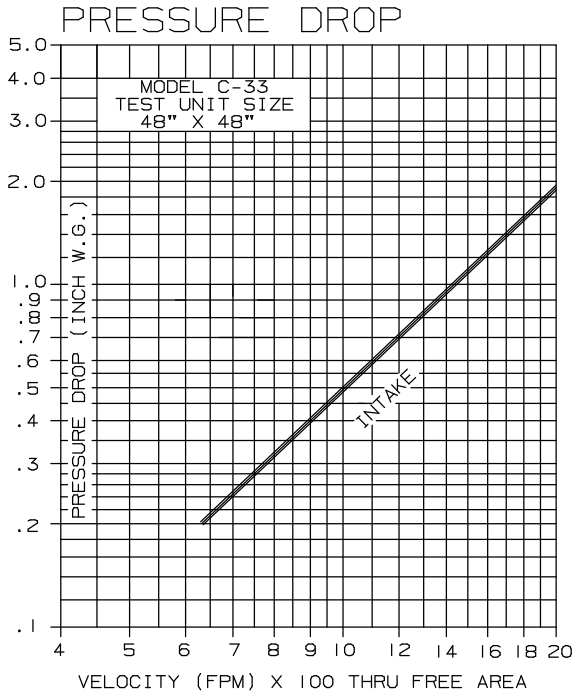

FREE AREA

HEIGHT	FREE AREA (SQ. FT.)								
	WIDTH								
	12"	18"	24"	30"	36"	42"	48"	54"	60"
12"	.27	.40	.53	.67	.80	.93	1.07	1.20	1.33
24"	.70	1.04	1.39	1.74	2.09	2.43	2.78	3.13	3.48
36"	1.13	1.69	2.25	2.81	3.38	3.94	4.50	5.06	5.63
48"	1.55	2.33	3.11	3.89	4.66	5.44	6.22	6.99	7.77
60"	1.98	2.98	3.97	4.96	5.95	6.94	7.93	8.93	9.92
72"	2.41	3.62	4.83	6.03	7.24	8.45	9.65	10.86	12.07
84"	2.84	4.26	5.68	7.11	8.53	9.95	11.37	12.79	14.21
96"	3.27	4.91	6.54	8.18	9.82	11.45	13.09	14.72	16.36