

FIRE/SEAL® UL-CLASSIFIED 3-HR. STATIC RATED FIRE DAMPER

MODEL 317A
Vertical & Horizontal

Classified by Underwriters Laboratories as a 3-hour fire protection rated Fire Damper, FOR USE IN STATIC SYSTEMS, in accordance with Standards UL-555 and NFPA-90A, for the protection of openings in fire partitions having a fire resistance rating of 3 hours or more.

VERTICAL MOUNT

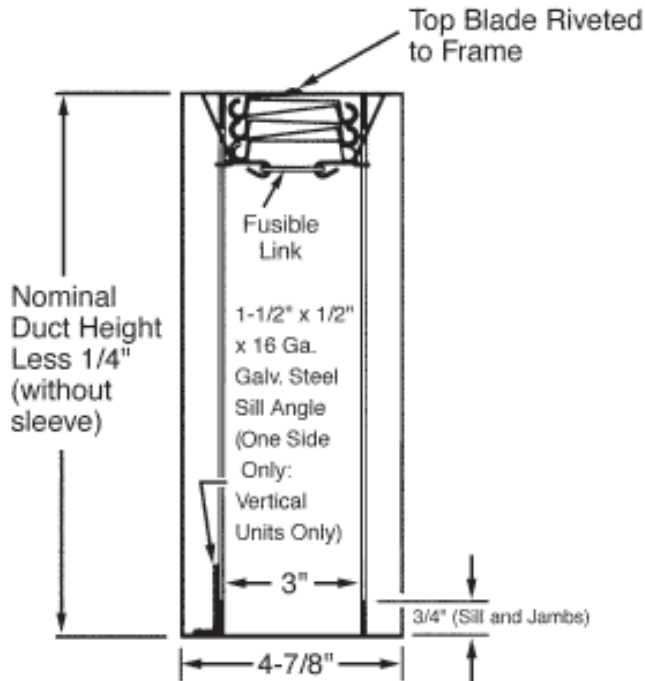

HORIZONTAL MOUNT

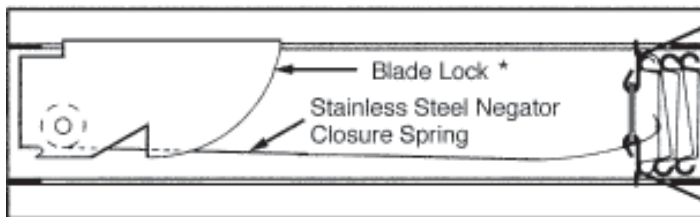

(*): Damper to be installed with blade lock points facing DOWNWARD and with access from above.

UNDERWRITERS LABORATORIES
INC.
CLASSIFIED
FIRE DAMPERS
FIRE RESISTANCE RATING **3 HR.**

SEE U.L. CLASSIFIED BUILDING MATERIALS INDEX
California State Fire Marshal
Listing No. 3225-1328:101

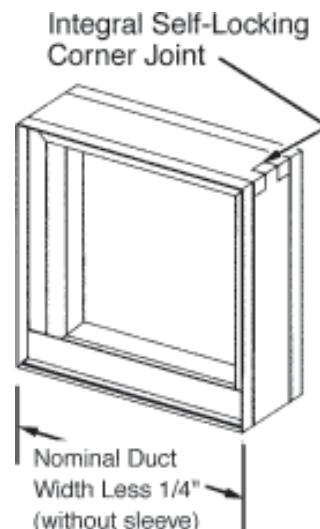

DIMENSIONAL DATA:

- MINIMUM SIZE:** 4" W x 4" H.
- MAXIMUM SIZE - VERTICAL (Galvanized Steel):**
Single Panel: 36" W x 32" H.
Multiple Panel: 72" W x 72" H;
in max. panels of 36" W x 36" H.
- MAXIMUM SIZE - VERTICAL (Stainless Steel):**
Single Panel: 47" W x 48" H.
Multiple Panel: 93" W x 48" H;
in max. panels of 47" W x 48" H.
- MAXIMUM SIZE - HORIZONTAL (Galvanized Steel):**
Single Panel: 48" W x 48" H.
Multiple Panel: 72" W x 36" H.
in max. panels of 36" W x 36" H.

NOTE: Unassembled multiple units do not include mullions.

- PROJECT:**
- LOCATION:**
- ARCHITECT:**
- ENGINEER:**
- CONTRACTOR:**
- PO NUMBER:**
- DATE:**

STANDARD MATERIALS & CONSTRUCTION:

- FRAME:** One-piece rollformed 22-Ga. galvanized steel.
- BLADES:** 22-Ga. galvanized steel curtain-type.
- FUSIBLE LINK:** UL-listed 165°F; replaceable. (Optional 212°F available at no additional charge.)
- CLOSURE SPRINGS (Horizontal Models):** Heat-treated Type 301 stainless steel constant force coiled negator type.



Arrow United Industries
A Division of Mestek, Inc.
314 Riverside Drive • Wyalusing, PA 18853
Ph: (570)-746-1888 Fax: (570)-746-9286
www.arrowunited.com
MEMBER OF AMCA

Additional information on reverse side.

ARROW UNITED INDUSTRIES SUBMITTAL DATA

FIRE/SEAL® UL-CLASSIFIED
3-HR. STATIC RATED FIRE DAMPER

MODEL 317A

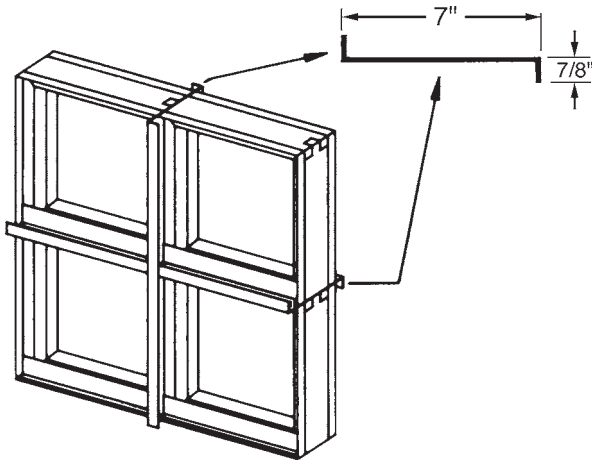

14 Ga. "ZEE MULLION" required for Multiple Panel Vertical Mount Dampers (Model 317AV) only.
Note: Minimum sleeve length is 9".

AVAILABLE OPTIONS:

1. Factory-supplied sleeves (20-Ga. through 10-Ga.).
2. Type 304 stainless steel construction (available for Vertical Mount dampers only).
3. 212°F fusible link.
4. Electro Thermal Link [ETL®].
5. SPDT "closed damper" position indicator switch.

VERTICAL (MODEL 317AV)

FREE AREA [sq. ft.] Duct Width (in.)

Duct Height (in.)	FREE AREA [sq. ft.] Duct Width (in.)											
	4	8	12	16	20	24	28	32	36	40	44	47
4	.02	.06	.08	.13	.16	.20	.22	.26	.30	.33	.37	.40
8	.08	.19	.32	.48	.59	.72	.85	1.0	1.2	1.3	1.4	1.5
12	.16	.35	.60	.75	1.0	1.2	1.5	1.7	2.0	2.2	2.4	2.6
16	.19	.52	.79	1.0	1.4	1.7	2.0	2.3	2.7	3.1	3.4	3.6
20	.27	.65	1.0	1.4	1.9	2.1	2.6	3.0	3.5	4.0	4.5	4.8
24	.33	.84	1.1	1.7	2.2	2.8	3.1	3.6	4.2	4.8	5.3	5.7
28	.37	.95	1.4	2.0	2.6	3.2	4.0	4.4	5.0	5.9	6.4	6.9
32	.45	1.1	1.7	2.2	3.0	4.0	4.7	5.1	5.7	6.5	7.2	7.8
36	.49	1.2	2.0	2.6	3.5	4.5	5.2	6.0	7.1	7.7	8.1	8.9
40	.54	1.4	2.3	3.0	4.0	5.0	6.0	6.8	7.9	8.7	9.0	10.0
44	.58	1.6	2.5	3.3	4.4	5.4	6.6	7.7	8.5	9.5	10.2	11.1
48	.64	1.7	2.7	3.8	5.0	6.0	6.9	8.0	9.3	10.6	11.3	12.5

HORIZONTAL (MODEL 317AH)

FREE AREA [sq. ft.] Duct Width (in.)

Duct Height (in.)	FREE AREA [sq. ft.] Duct Width (in.)											
	4	8	12	16	20	24	28	32	36	40	44	48
4	.03	.09	.1	.2	.3	.3	.4	.4	.5	.6	.6	.7
8	.1	.2	.4	.6	.7	.9	1.0	1.2	1.4	1.5	1.7	1.8
12	.2	.4	.7	.9	1.2	1.5	1.8	2.0	2.3	2.6	2.8	3.1
16	.2	.6	.9	1.3	1.7	2.0	2.4	2.8	3.1	3.5	3.9	4.2
20	.3	.7	1.2	1.7	2.1	2.6	3.1	3.5	4.0	4.5	5.0	5.4
24	.4	.9	1.4	2.0	2.6	3.2	3.7	4.3	4.9	5.4	6.0	6.6
28	.4	1.0	1.7	2.4	3.0	3.7	4.4	5.0	5.7	6.4	7.0	7.7
32	.5	1.2	2.0	2.7	3.5	4.3	5.1	5.8	6.6	7.4	8.2	9.0
36	.5	1.3	2.2	3.1	4.0	4.8	5.7	6.6	7.4	8.4	9.2	10.1
40	.6	1.5	2.5	3.5	4.4	5.4	6.4	7.4	8.4	9.3	10.3	11.3
44	.6	1.7	2.7	3.8	4.9	6.0	7.0	8.1	9.2	10.3	11.4	12.4
48	.7	1.8	3.0	4.2	5.4	6.6	7.7	8.9	10.1	11.3	12.5	13.7

$$\text{FREE AREA VELOCITY [fpm]} = \frac{\text{FLOW [cfm]}}{\text{FREE AREA [sq. ft.]}}$$

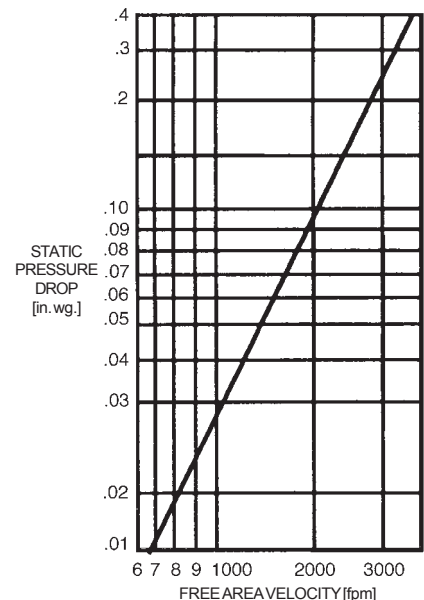

IN THE INTEREST OF PRODUCT DEVELOPMENT, ARROW UNITED INDUSTRIES RESERVES THE RIGHT TO MAKE CHANGES WITHOUT NOTICE.



Arrow United Industries
A Division of Mestek, Inc.
314 Riverside Drive • Wyalusing, PA 18853
Ph: (570)-746-1888 Fax: (570)-746-9286
www.arrowunited.com