

# INSTALLATION INSTRUCTIONS

## FIRE/LEAKAGE RATED CORRIDOR DAMPERS

### MODEL AS2C250

AII-AS2C-03.1

#### APPLICATION

This Corridor Damper is Classified by Underwriters Laboratories for One Hour Fire Resistance and as a Class II 250°F Leakage Rated Damper to UL Standard 555S. This damper is to be mounted horizontally into ceilings of fire rated corridors where permitted by the Authority Having Jurisdiction. Minimum ceiling construction requirements are illustrated later in this booklet. This damper is supplied with a factory mounted actuator and is intended to close automatically when sensing elevated temperature or upon loss of electrical power. Damper will close within 15 seconds. If closed due to loss of electrical power, the damper will reopen when electrical power is restored. An aluminum or steel grille can be installed below the damper as long as the grille does not interfere with the closure of the damper.

#### Wiring Diagram

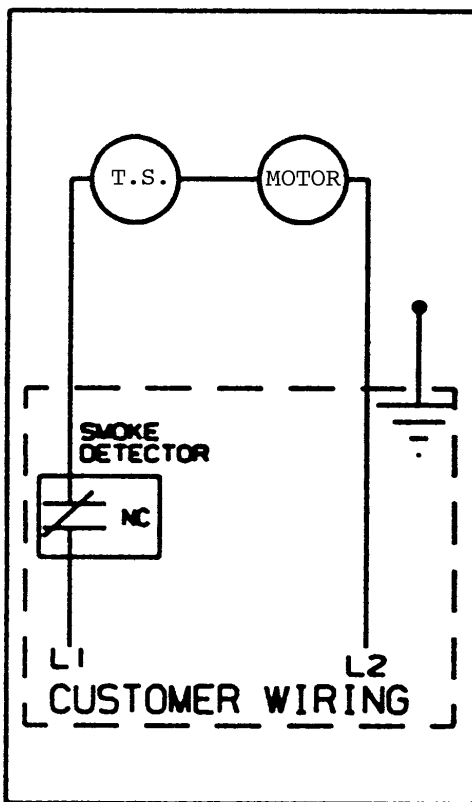

#### INSTALLATION

Several methods of installing this damper are illustrated in this booklet. Depending on method chosen, expansion clearance and perimeter mounting angles may not be required. Regardless of installation method used, the damper frame is to be square and not distorted. Frame distortion can result in reduced leakage resistance or incomplete closure.

1. The installation of the damper and all duct connections to the damper sleeve shall conform to NFPA-90A and the SMACNA Fire, Smoke and Radiation Damper Installation Guide. All duct connections shall also conform to UL555.
2. Sleeves shall be the same gauge or heavier as the duct to which it is attached. Gauges shall conform to SMACNA duct standards.
3. The damper is supplied with a factory attached sleeve. Duct connections to the sleeve will be either of the breakaway or rigid types that are listed below. The following determines if the connections are to be rigid or breakaway. For rigid type duct connections, sleeve shall be a minimum of 16 GA. Maximum sleeve thickness will not exceed 10 GA. galvanized steel. Dampers supplied with thinner sleeves will require a breakaway connection of the types listed in Note 5. The standard factory supplied sleeve is 20 GA. galvanized steel and assumes that a breakaway type duct connection will be employed.
4. Duct connections not listed as breakaways (See Note 5) shall be considered rigid. Breakaway joints shall have no more than two No. 10 sheet metal screws on each side and on the bottom. The screws shall penetrate both sides of the slip pocket. When a breakaway joint is used along the top and bottom duct connection, a flat drive slip no longer than 20 inches is permitted on the two sides.

These Installation Instructions comply with Underwriters Laboratories Inc. Safety Standard 555 and 555S.



Arrow United Industries  
A Division of Mestek, Inc.  
314 Riverside Drive • Wyalusing, PA 18853

## Installations (Con't.)

5. The following breakaway duct-to-sleeve connections may be used: Plain "S" Slip, Double "S" Slip, Inside Slip Joint, Hemmed "S" Slip, Standing "S" Slip (Bar Reinforced), Standing "S" slip (Angle Reinforced) and Standing "S" Slip (Alternate Bar).
6. All connecting ducts shall not be continuous but shall terminate at the fire damper sleeve. Connecting ducts are attached to the damper sleeve as instructed by Notes 3, 4 and 5.
7. Ducts connected to round or flat oval transitions are connected either with a four inch wide draw band or by attaching the duct to the factory supplied transition collar with a maximum of three equally spaced No. 10 sheet metal screws.
8. Various brands of manufactured flanged connections can be used as breakaway connections as long as they are installed as shown by Figure 5-2 of the 5th Edition of SMACNA's Fire, Smoke and Radiation Damper Installation Guide.

## ELECTRICAL CONNECTIONS

### Electrical Connections and sequence of operations for fire/leakage rated Corridor Damper. Damper supplied with one manually resettable thermal device.

---

#### Read Before Installation

1. Make sure that the electrical thermal device has been set. Simply push the red button located by the motor.
2. All wiring to be in accordance with N.E.C. (NFPA-70).
3. Identify actuator model number, check its operating voltage and current requirements. This information is shown on a label on or near the actuator.
4. Electrical supply is connected to terminals L1 and L2, reference wiring schematic. Connect the incoming ground to the wiring enclosure.
5. If a smoke detector or other sensing device is to be employed, it should be wired in series with L1 and the damper.
6. Circuit test:
  - A. Caution-when operating damper, keep fingers and clothing away from damper blades.
  - B. Make sure that the proper electrical power source has been supplied; 24VAC or 120VAC.
  - C. Apply power, the damper blades should open.
  - D. Disconnect power; the damper blades should close.
  - E. To check the electric resettable thermo device;
    1. Apply electrical power (damper blades opened).
    2. Hold a lit match or lighter near the face of the thermal device. A faint click should be heard and the damper blades should close.
    3. After the thermal disc has cooled, push the red reset button and the damper blades should reopen.

ACTUATOR LOCATION	ACTUATOR MODEL NO.	VOLTAGE	MAX. VEL. (FPM)	MAX. TEMP. RATING	MAX. DAMPER SIZE W X H
Internal or External	*ML8115	24VAC	2000	250°F	24 x 24
Internal or External	*ML4115	120VAC	2000	250°F	24 x 24

\*A or B Suffix

UL CLASSIFIED 5/8" THICK GYPSUM WALLBOARD APPLIED TO EACH SIDE OF WOOD FRAMING ATTACHED WITH 6d NAILS 7" O.C. OR WITH 1-5/8" LONG DRYWALL SCREWS 12" O.C.

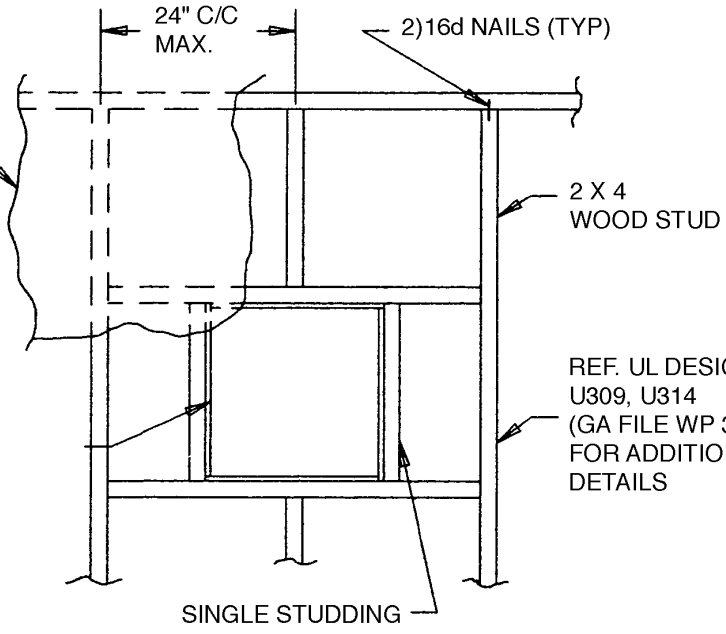

REF. UL DESIGNS U309, U314 (GA FILE WP 3510) FOR ADDITIONAL DETAILS

### WOOD FRAMING CONSTRUCTION (MIN. REQUIREMENTS)

UL CLASSIFIED 5/8" THICK GYPSUM WALLBOARD APPLIED TO EACH SIDE OF STEEL FRAMING ATTACHED WITH 1" DRYWALL SCREWS 12" O.C.

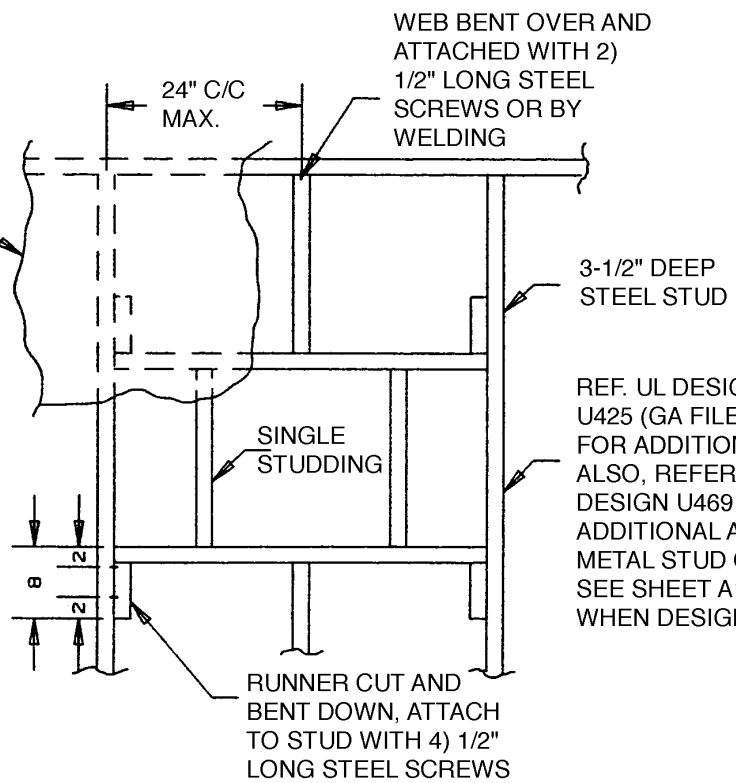

REF. UL DESIGN U425 (GA FILE WP 1206) FOR ADDITIONAL DETAILS. ALSO, REFERENCE UL DESIGN U469 FOR AN ADDITIONAL APPROVED METAL STUD CONSTRUCTION. SEE SHEET A10-27502 WHEN DESIGN U469 IS USED.

### STEEL FRAMING CONSTRUCTION (MIN. REQUIREMENTS)

XY26720Z  
DAD 11-7-94

WHEN ML-SERIES  
ACTUATOR IS PROVIDED

- \* 6-3/8
- \*\* 6-1/2

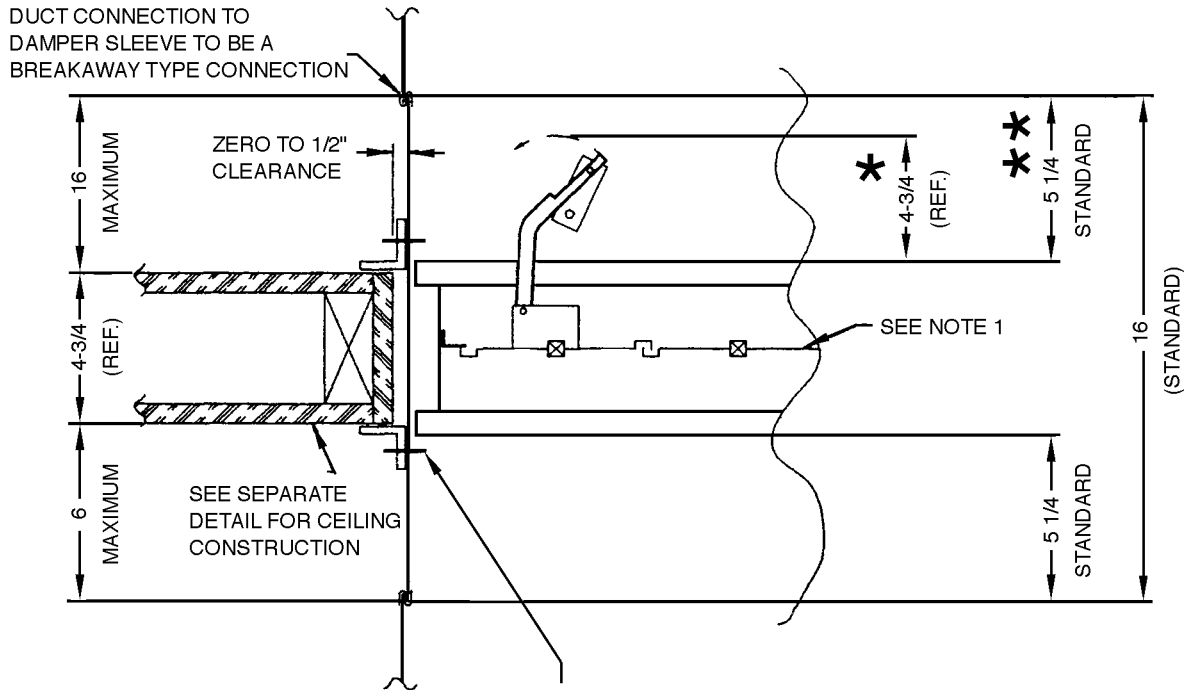

FASTEN THE PERIMETER MOUNTING ANGLES ON ALL FOUR SIDES OF THE DAMPER TO THE SLEEVE ONLY, WITH 1/4" DIAMETER STEEL OR STAINLESS STEEL NUTS AND BOLTS OR BY TACK WELDING WITH BEADS 1/2" ± 1/4" IN LENGTH OR WITH #10 STEEL OR STAINLESS STEEL SHEET METAL SCREWS OR 3/16" STEEL OR STAINLESS STEEL POP RIVETS. ALL CONNECTIONS SHALL BE SPACED A MAXIMUM OF 8" ON CENTER AND SHALL HAVE A CONNECTION NOT MORE THAN 3" FROM EACH CORNER. PERIMETER MOUNTING ANGLES SHALL BE A MINIMUM OF 1 X 1 X 16 GA. STEEL AND LAP THE CEILING BY A MINIMUM OF 1". THE CORNERS OF THE PERIMETER MOUNTING ANGLES CAN BE WELDED. SOME LOCAL CODES MAY NOT ALLOW WELDED CORNERS. PERIMETER ANGLES AND THEIR MOUNTING FASTENERS ARE NOT NORMALLY SUPPLIED WITH THE DAMPER. ATTACHMENT OF THESE ANGLES MUST NOT RESTRICT OPERATION OF THE DAMPER.

NOTES:

1. CLOSED PLANE OF DAMPER BLADES MUST BE WITHIN THE CEILING OR NO MORE THAN 1-1/2" AWAY FROM THE FACE OF THE CEILING.
2. SHOWN INSTALLED IN WOOD FRAMING. INSTALLATION IN STEEL FRAMING IS SIMILAR.

NON-FLANGED SLEEVE

XY26725Z  
DAD

WHEN ML-SERIES ACTUATOR IS PROVIDED

\* 6-3/8  
\*\* 15-1/4

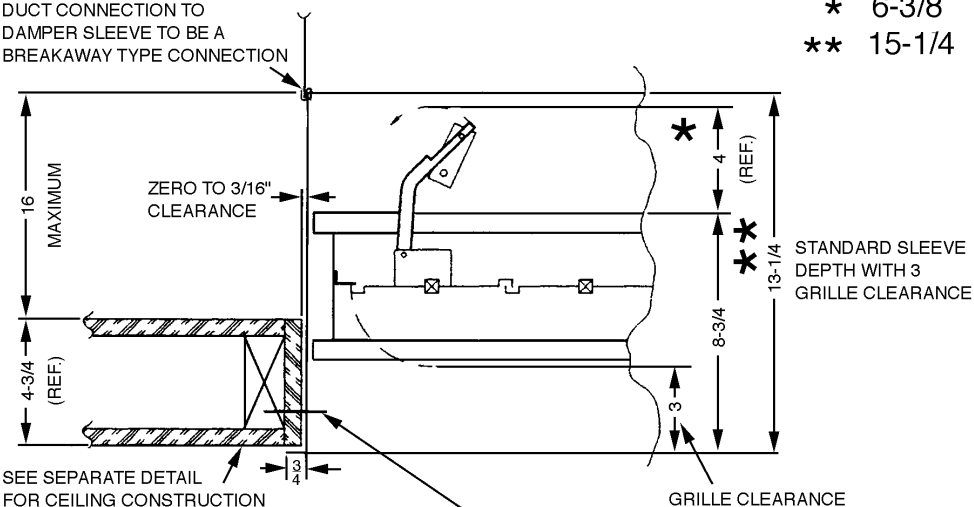

NOTE:  
SHOWN INSTALLED IN WOOD FRAMING. INSTALLATION IN STEEL FRAMING IS SIMILAR. WHEN STEEL FRAMING, OPENING NEED NOT BE LINED WITH GYPSUM BOARD. WHEN STEEL FRAMING AND NO OPENING LINING, #12 X 1" LONG (MINIMUM) STEEL SHEET METAL SCREWS 6" MAXIMUM O.C., 3" MAXIMUM FROM CORNERS. WHEN STEEL FRAMING AND OPENING LINING, SCREWS TO BE 1-1/2" MINIMUM LENGTH.

10 d STEEL NAILS OR #12 X 2" 1g STEEL SCREWS 6" MAXIMUM O.C., 3" MAXIMUM FROM CORNERS. NAILS TO BE SET SO AS NOT TO DISTORT DAMPER SLEEVE. FRAME DISTORTION CAN RESULT IN REDUCED LEAKAGE RESISTANCE OR INCOMPLETE CLOSURE. WHEN THE 3/4" FLANGES ARE SHIPPED LOOSE, USE THE SAME FASTENERS TO ATTACH THE FLANGES THAT ATTACH THE DAMPER TO THE FRAMING.

**FLANGE EXPOSED, NO PERIMETER MOUNTING ANGLES, 3" GRILLE CLEARANCE**  
**Not Approved for the City of Los Angeles**

WHEN ML-SERIES ACTUATOR IS PROVIDED

\* 6-3/8  
\*\* 14

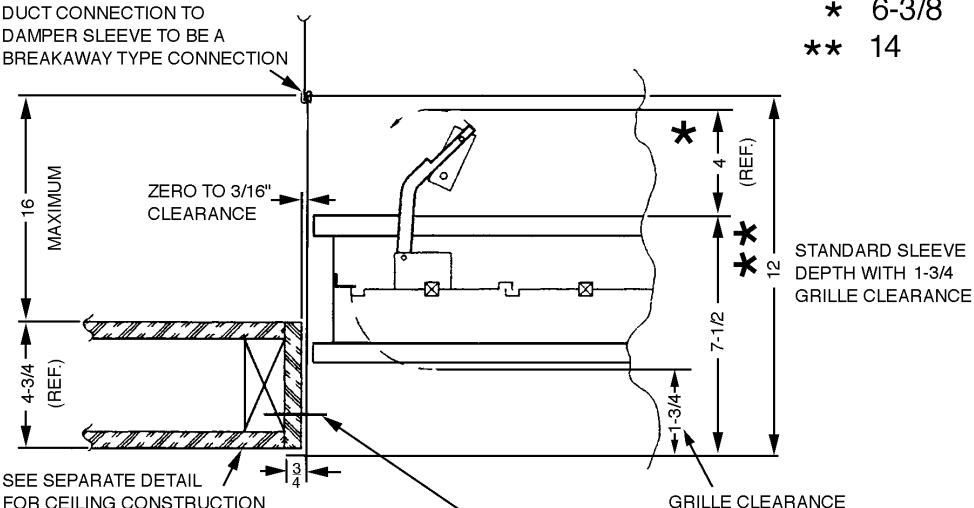

NOTE:  
SHOWN INSTALLED IN WOOD FRAMING. INSTALLATION IN STEEL FRAMING IS SIMILAR. WHEN STEEL FRAMING, OPENING NEED NOT BE LINED WITH GYPSUM BOARD. WHEN STEEL FRAMING AND NO OPENING LINING, #12 X 1" LONG (MINIMUM) STEEL SHEET METAL SCREWS 6" MAXIMUM O.C., 3" MAXIMUM FROM CORNERS. WHEN STEEL FRAMING AND OPENING LINING, SCREWS TO BE 1-1/2" MINIMUM LENGTH.

10 d STEEL NAILS OR #12 X 2" 1g STEEL SCREWS 6" MAXIMUM O.C., 3" MAXIMUM FROM CORNERS. NAILS TO BE SET SO AS NOT TO DISTORT DAMPER SLEEVE. FRAME DISTORTION CAN RESULT IN REDUCED LEAKAGE RESISTANCE OR INCOMPLETE CLOSURE. WHEN THE 3/4" FLANGES ARE SHIPPED LOOSE, USE THE SAME FASTENERS TO ATTACH THE FLANGES THAT ATTACH THE DAMPER TO THE FRAMING.

**FLANGE EXPOSED, NO PERIMETER MOUNTING ANGLES, 1-3/4" GRILLE CLEARANCE**  
**Not Approved for the City of Los Angeles**

WHEN ML-SERIES  
ACTUATOR IS PROVIDED

\* 6-3/8  
\*\* 15-1/4

DUCT CONNECTION TO  
DAMPER SLEEVE TO BE A  
BREAKAWAY TYPE CONNECTION

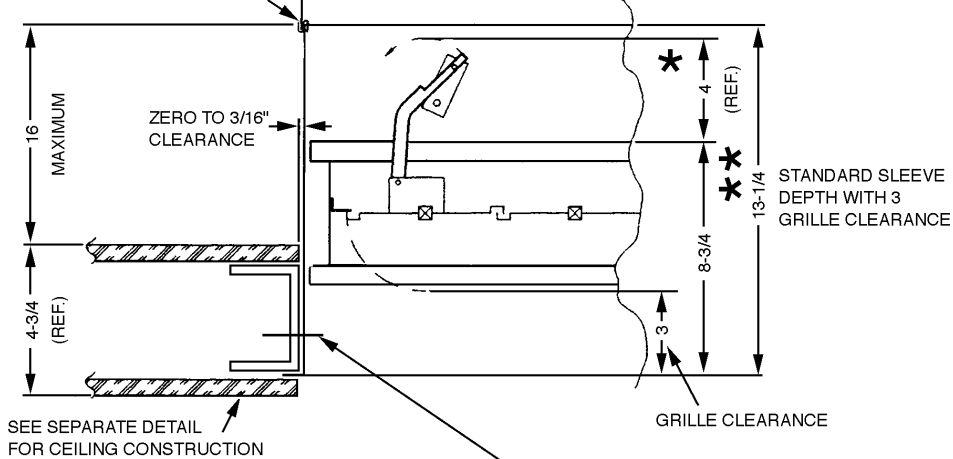

NOTE:

STEEL FRAMING ONLY, OPENING NEED NOT BE LINED WITH GYPSUM BOARD. WHEN STEEL FRAMING AND LINING, DAMPER ATTACHED TO FRAMING WITH #12 X 1-1/2" LONG STEEL SHEET METAL SCREWS 6" MAXIMUM O.C., 3" MAXIMUM FROM CORNERS.

#12 x 1" LONG STEEL SHEET METAL SCREWS 6" MAXIMUM O.C., 3" MAXIMUM FROM CORNERS. SCREWS TO BE SET SO AS NOT TO DISTORT DAMPER SLEEVE. DAMPER SLEEVE FRAME DISTORTION CAN RESULT IN REDUCED LEAKAGE RESISTANCE OR INCOMPLETE CLOSURE. WHEN THE 3/4" FLANGES ARE SHIPPED LOOSE, USE THE SAME FASTENERS TO ATTACH THE FLANGES THAT ATTACH THE DAMPER TO THE FRAMING.

FLANGE CONCEALED, NO PERIMETER MOUNTING  
ANGLES, 3" GRILLE CLEARANCE

**Not Approved for the City of Los Angeles**

WHEN ML-SERIES  
ACTUATOR IS PROVIDED

\* 6-3/8  
\*\* 14

DUCT CONNECTION TO  
DAMPER SLEEVE TO BE A  
BREAKAWAY TYPE CONNECTION

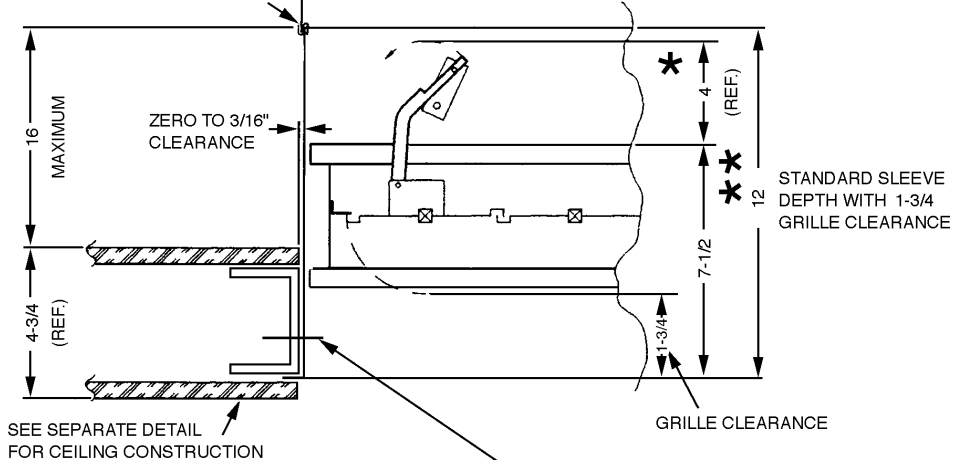

NOTE:

STEEL FRAMING ONLY, OPENING NEED NOT BE LINED WITH GYPSUM BOARD. WHEN STEEL FRAMING AND LINING, DAMPER ATTACHED TO FRAMING WITH #12 X 1-1/2" LONG STEEL SHEET METAL SCREWS 6" MAXIMUM O.C., 3" MAXIMUM FROM CORNERS.

#12 x 1" LONG STEEL SHEET METAL SCREWS 6" MAXIMUM O.C., 3" MAXIMUM FROM CORNERS. SCREWS TO BE SET SO AS NOT TO DISTORT DAMPER SLEEVE. DAMPER SLEEVE FRAME DISTORTION CAN RESULT IN REDUCED LEAKAGE RESISTANCE OR INCOMPLETE CLOSURE. WHEN THE 3/4" FLANGES ARE SHIPPED LOOSE, USE THE SAME FASTENERS TO ATTACH THE FLANGES THAT ATTACH THE DAMPER TO THE FRAMING.

FLANGE CONCEALED, NO PERIMETER MOUNTING  
ANGLES, 1-3/4" GRILLE CLEARANCE

**Not Approved for the City of Los Angeles**

DUCT CONNECTION TO DAMPER SLEEVE TO BE A BREAKAWAY TYPE CONNECTION.

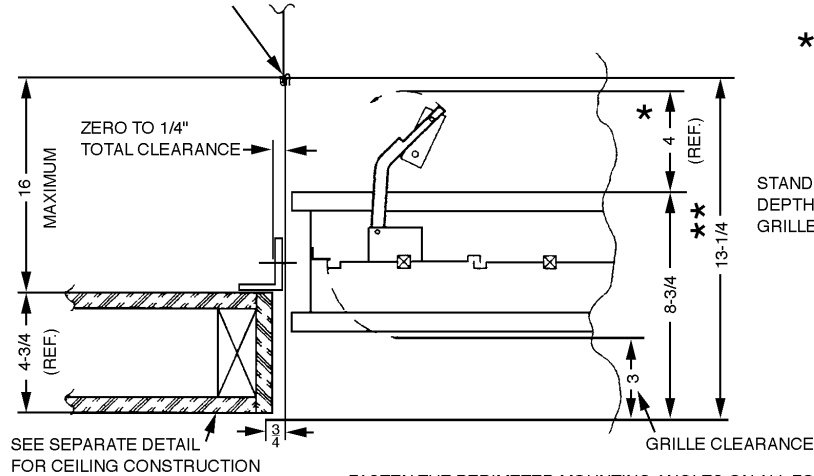

NOTE:  
SHOWN INSTALLED IN WOOD FRAMING. INSTALLATION IN STEEL FRAMING IS SIMILAR.

FASTEN THE PERIMETER MOUNTING ANGLES ON ALL FOUR SIDES OF THE DAMPER TO THE SLEEVE ONLY, WITH 1/4" DIAMETER STEEL OR STAINLESS STEEL NUTS AND BOLTS OR BY TACK WELDING WITH BEADS 1/2" ± 1/4" IN LENGTH OR WITH #10 STEEL OR STAINLESS STEEL SHEET METAL SCREWS OR 3/16" STEEL OR STAINLESS STEEL POP RIVETS. ALL CONNECTIONS SHALL BE SPACED A MAXIMUM OF 8" ON CENTER AND SHALL HAVE A CONNECTION NOT MORE THAN 3" FROM EACH CORNER. PERIMETER MOUNTING ANGLES SHALL BE A MINIMUM OF 1 X 1 X 16 ga STEEL AND LAP THE CEILING BY A MINIMUM OF 1". THE CORNERS OF THE PERIMETER MOUNTING ANGLES CAN BE WELDED. PERIMETER ANGLES AND THEIR MOUNTING FASTENERS ARE NOT NORMALLY SUPPLIED WITH THE DAMPER. ATTACHMENT OF THESE ANGLES MUST NOT RESTRICT OPERATION OF THE DAMPER.

WHEN ML-SERIES ACTUATOR IS PROVIDED

- \* 6-3/8
- \*\* 15-1/4

STANDARD SLEEVE DEPTH WITH 3 GRILLE CLEARANCE.

FLANGE EXPOSED, PERIMETER MOUNTING ANGLES, 3" GRILLE CLEARANCE

DUCT CONNECTION TO DAMPER SLEEVE TO BE A BREAKAWAY TYPE CONNECTION.

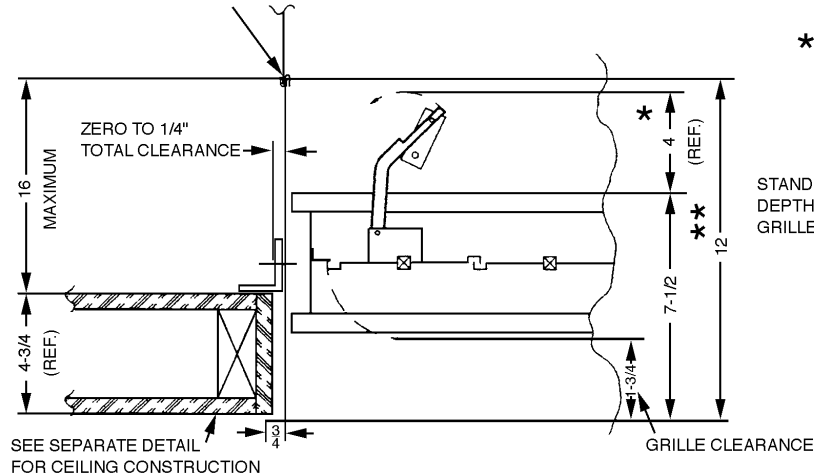

NOTE:  
SHOWN INSTALLED IN WOOD FRAMING. INSTALLATION IN STEEL FRAMING IS SIMILAR.

FASTEN THE PERIMETER MOUNTING ANGLES ON ALL FOUR SIDES OF THE DAMPER TO THE SLEEVE ONLY, WITH 1/4" DIAMETER STEEL OR STAINLESS STEEL NUTS AND BOLTS OR BY TACK WELDING WITH BEADS 1/2" ± 1/4" IN LENGTH OR WITH #10 STEEL OR STAINLESS STEEL SHEET METAL SCREWS OR 3/16" STEEL OR STAINLESS STEEL POP RIVETS. ALL CONNECTIONS SHALL BE SPACED A MAXIMUM OF 8" ON CENTER AND SHALL HAVE A CONNECTION NOT MORE THAN 3" FROM EACH CORNER. PERIMETER MOUNTING ANGLES SHALL BE A MINIMUM OF 1 X 1 X 16 ga STEEL AND LAP THE CEILING BY A MINIMUM OF 1". THE CORNERS OF THE PERIMETER MOUNTING ANGLES CAN BE WELDED. PERIMETER ANGLES AND THEIR MOUNTING FASTENERS ARE NOT NORMALLY SUPPLIED WITH THE DAMPER. ATTACHMENT OF THESE ANGLES MUST NOT RESTRICT OPERATION OF THE DAMPER.

WHEN ML-SERIES ACTUATOR IS PROVIDED

- \* 6-3/8
- \*\* 14

STANDARD SLEEVE DEPTH WITH 3 GRILLE CLEARANCE.

FLANGE EXPOSED, PERIMETER MOUNTING ANGLES, 1-3/4" GRILLE CLEARANCE

DUCT CONNECTION TO DAMPER SLEEVE TO BE A BREAKAWAY TYPE CONNECTION

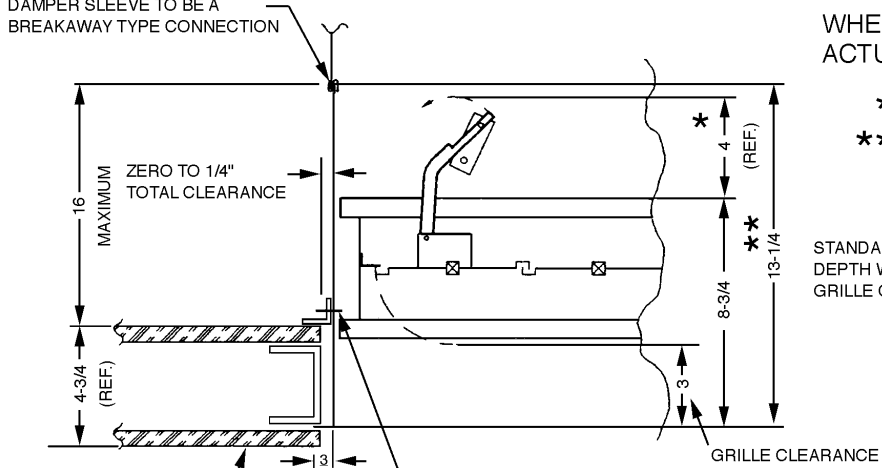

SEE SEPARATE DETAIL FOR CEILING CONSTRUCTION

NOTE:  
STEEL FRAMING ONLY, OPENING NEED NOT BE LINED WITH GYPSUM BOARD

FASTEN THE PERIMETER MOUNTING ANGLES ON ALL FOUR SIDES OF THE DAMPER TO THE SLEEVE ONLY, WITH 1/4" DIAMETER STEEL OR STAINLESS STEEL NUTS AND BOLTS OR BY TACK WELDING WITH BEADS 1/2" ± 1/4" IN LENGTH OR WITH #10 STEEL OR STAINLESS STEEL SHEET METAL SCREWS OR 3/16" STEEL OR STAINLESS STEEL POP RIVETS. ALL CONNECTIONS SHALL BE SPACED A MAXIMUM OF 8" ON CENTER AND SHALL HAVE A CONNECTION NOT MORE THAN 3" FROM EACH CORNER. PERIMETER MOUNTING ANGLES SHALL BE A MINIMUM OF 1 X 1 X 16 ga STEEL AND LAP THE CEILING BY A MINIMUM OF 1". THE CORNERS OF THE PERIMETER MOUNTING ANGLES CAN BE WELDED. PERIMETER ANGLES AND THEIR MOUNTING FASTENERS ARE NOT NORMALLY SUPPLIED WITH THE DAMPER. ATTACHMENT OF THESE ANGLES MUST NOT RESTRICT OPERATION OF THE DAMPER.

WHEN ML-SERIES ACTUATOR IS PROVIDED

- \* 6-3/8
- \*\* 15-1/4

STANDARD SLEEVE DEPTH WITH 3 GRILLE CLEARANCE

FLANGE CONCEALED, PERIMETER MOUNTING ANGLE, 3" GRILLE CLEARANCE

DUCT CONNECTION TO DAMPER SLEEVE TO BE A BREAKAWAY TYPE CONNECTION

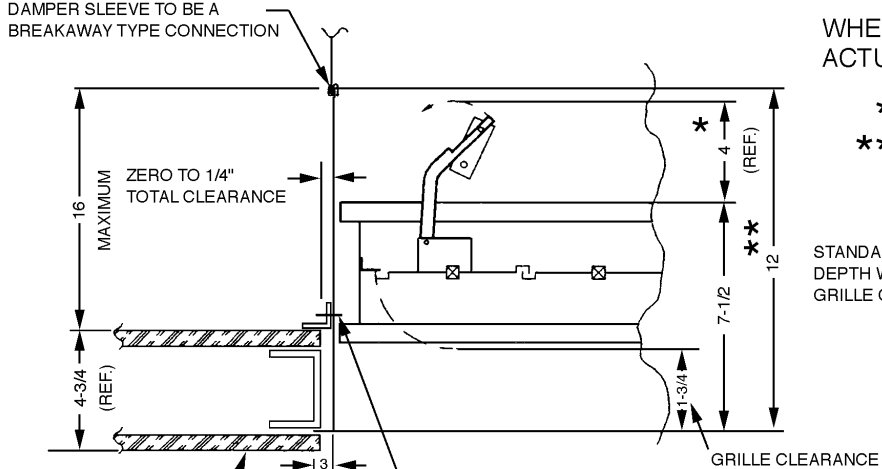

SEE SEPARATE DETAIL FOR CEILING CONSTRUCTION

NOTE:  
STEEL FRAMING ONLY, OPENING NEED NOT BE LINED WITH GYPSUM BOARD

FASTEN THE PERIMETER MOUNTING ANGLES ON ALL FOUR SIDES OF THE DAMPER TO THE SLEEVE ONLY, WITH 1/4" DIAMETER STEEL OR STAINLESS STEEL NUTS AND BOLTS OR BY TACK WELDING WITH BEADS 1/2" ± 1/4" IN LENGTH OR WITH #10 STEEL OR STAINLESS STEEL SHEET METAL SCREWS OR 3/16" STEEL OR STAINLESS STEEL POP RIVETS. ALL CONNECTIONS SHALL BE SPACED A MAXIMUM OF 8" ON CENTER AND SHALL HAVE A CONNECTION NOT MORE THAN 3" FROM EACH CORNER. PERIMETER MOUNTING ANGLES SHALL BE A MINIMUM OF 1 X 1 X 16 ga STEEL AND LAP THE CEILING BY A MINIMUM OF 1". THE CORNERS OF THE PERIMETER MOUNTING ANGLES CAN BE WELDED. PERIMETER ANGLES AND THEIR MOUNTING FASTENERS ARE NOT NORMALLY SUPPLIED WITH THE DAMPER. ATTACHMENT OF THESE ANGLES MUST NOT RESTRICT OPERATION OF THE DAMPER.

WHEN ML-SERIES ACTUATOR IS PROVIDED

- \* 6-3/8
- \*\* 14

STANDARD SLEEVE DEPTH WITH 1-3/4 GRILLE CLEARANCE

FLANGE CONCEALED, PERIMETER MOUNTING ANGLE, 1-3/4" GRILLE CLEARANCE