

THERMAL BLANKET

**For Lay-In Diffuser/Grille Installations Of
UL-CLASSIFIED CEILING DAMPERS**

**UTILIZES CEILING
DAMPER MODEL NO.:**

- A89
- A91
- A93
- A95
- A97

**REFER TO CEILING
DAMPER SUBMITTAL NO.:**

- AD-A89
- AD-A91
- AD-A93
- AD-A95
- AD-A97

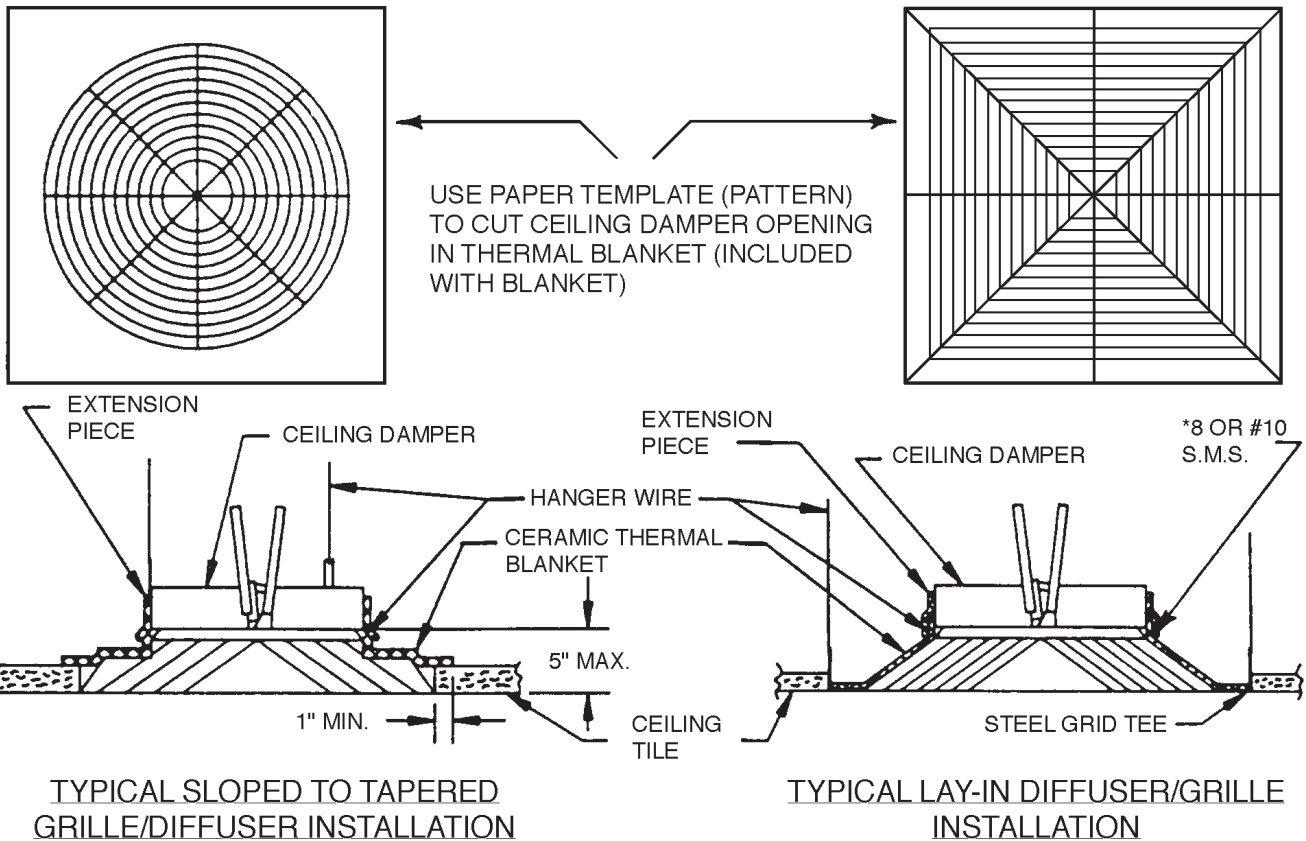

See Reverse Side for **INFORMATIONAL DATA.**

PROJECT:
LOCATION:
ARCHITECT:
ENGINEER:

CONTRACTOR:
P. O. NUMBER:
DATE:

ARROW UNITED INDUSTRIES SUBMITTAL DATA

THERMAL BLANKET

For Lay-In Diffuser/Grille Installations Of UL-CLASSIFIED CEILING DAMPERS

INFORMATIONAL DATA

- 1) A Thermal Blanket is required for ceiling dampers supported by a lay-in diffuser/grille.
- 2) The area below the plane of the ceiling damper blade down to the topside of the diffuser/grille must be insulated. Two methods of insulating this area may be employed when the topside of the diffuser/grille is flat and is raised no more than ½" from the face of the ceiling:
 - a) The first and most convenient method is to use a Thermal Blanket. Cut the desired hole, and lay the Thermal Blanket over the diffuser/grille. Next, take an extension piece of the blanket and wrap it around the damper/diffuser overlap connection. Secure it in place with the use of hanger wire. The Thermal Blanket should extend out to the tee grid on all four sides.
 - b) An alternative method is to use the same ceiling tile material as is used for the remainder of the ceiling. Although the tile must be cut to allow for the damper/diffuser overlap connection to pass through, the clearance between the tile and the tee grid and between the damper and the tile should not be greater than 1/4" total.

EXCEPTION: When the topside of the lay-in diffuser/grille is pitched or contains an obstruction of greater than ½" from the ceiling surface, the Thermal Blanket **MUST** be used.

- 3) When a opposed blade damper (OBD) is installed between the ceiling damper and the ceiling surface, be sure that the insulation covers the area below the plane of the damper blade down to the topside of the diffuser/grill.
- 4) When a sloped or tapered **surface-mount** diffuser/grille is used, the diffuser/grille **MUST** be insulated with a Thermal Blanket. The Thermal Blanket should provide insulation from the plane of the ceiling damper blade down to the top of the ceiling surface.
- 5) Arrow's Thermal Blanket is a 1/4" thick non-asbestos ceramic fiber, with 8 lbs./cu. ft. density. The blanket offers highly efficient insulation and possesses high tensile strength and resiliency to withstand vibration and physical abuse. It will not separate, sag, or settle. It is characterized by extreme resistance to thermal shock, and its thermal and physical properties are unaffected by oil or water after drying.



Arrow United Industries
A Division of Mestek, Inc.
314 Riverside Drive • Wyalusing, PA 18853
Ph: (570)-746-1888 Fax: (570)-746-9286
www.arrowunited.com

IN THE INTEREST OF PRODUCT DEVELOPMENT, ARROW UNITED
RESERVES THE RIGHT TO MAKE CHANGES WITHOUT NOTICE.